



Safety by Design



DMA

Phone: 705.446.2667 Fax: 705.446.2667
Email adavidson@dmatechnical.com
Box 2398, RR2, Collingwood, ON L9Y 3Z1

Technical Services Inc.

Phone: 519.351.8155 Fax: 519.351.8183
Email dma@dmatechnical.com website www.dmatechnical.com
330 Richmond St. Chatham, Ontario N7M 1P7 Canada



An Integral Part of DMA's Alternative Energy Infrastructure Development Model

Alternative Energy Infrastructure Project Management Manual

TABLE OF CONTENTS

Part 1 Project Administration

Part 2 Equipment

Part 3 Station Design

Part 4 Construction Contract and Specifications

Part 5 Approvals

Part 6 Safety

Part 7 Manuals / Training

Part 8 Warranty

Part 9 Public Participation

Part 6 - Safety

1. Project Safety Plan
2. Design Risk Analysis
3. Construction Risk Analysis
4. Operational Risk Analysis
5. Disposal Risk Analysis
6. Operational Readiness Checklist

DMA Approach to Alternative Fuels Safety

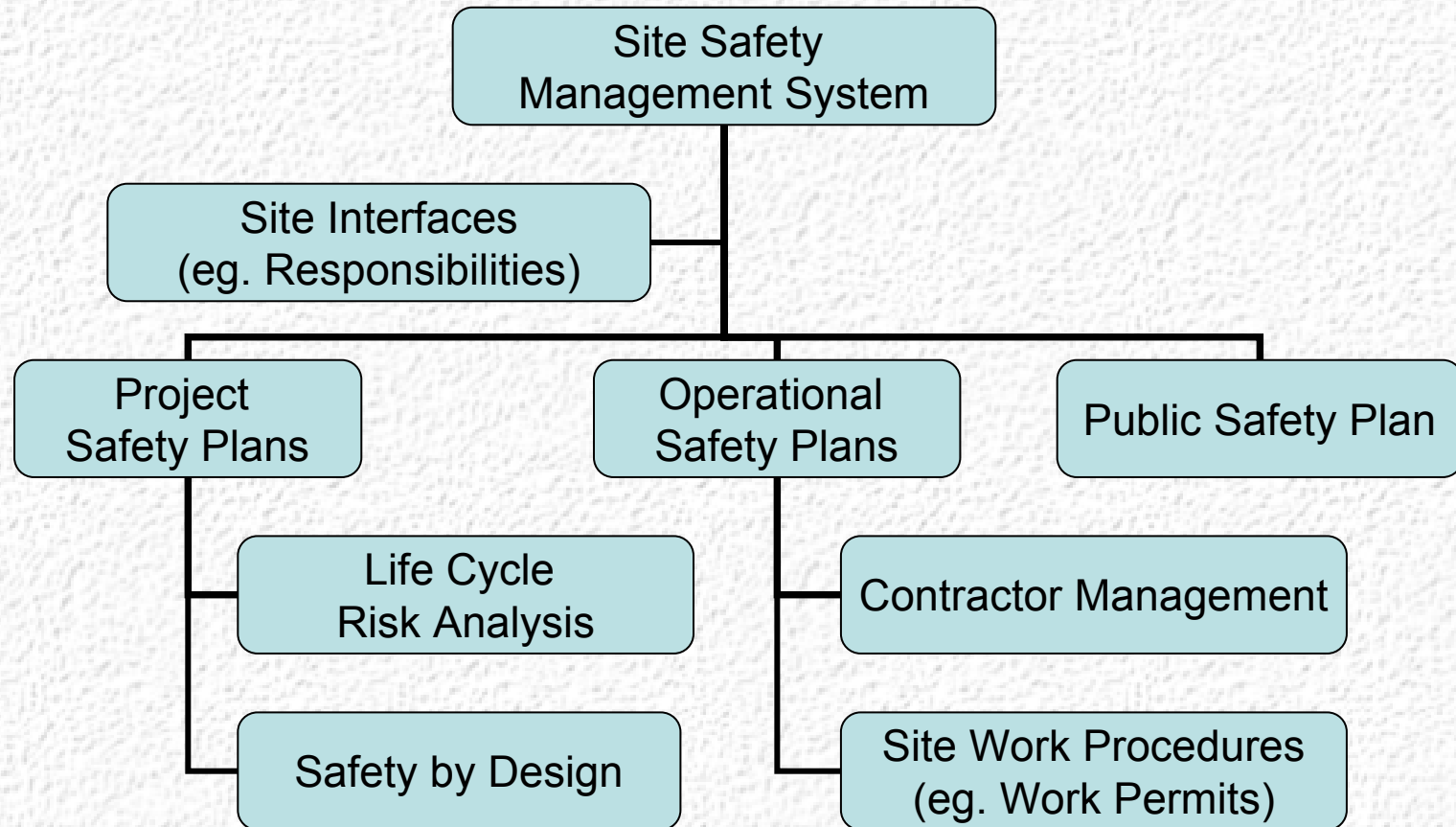

Safety Management System

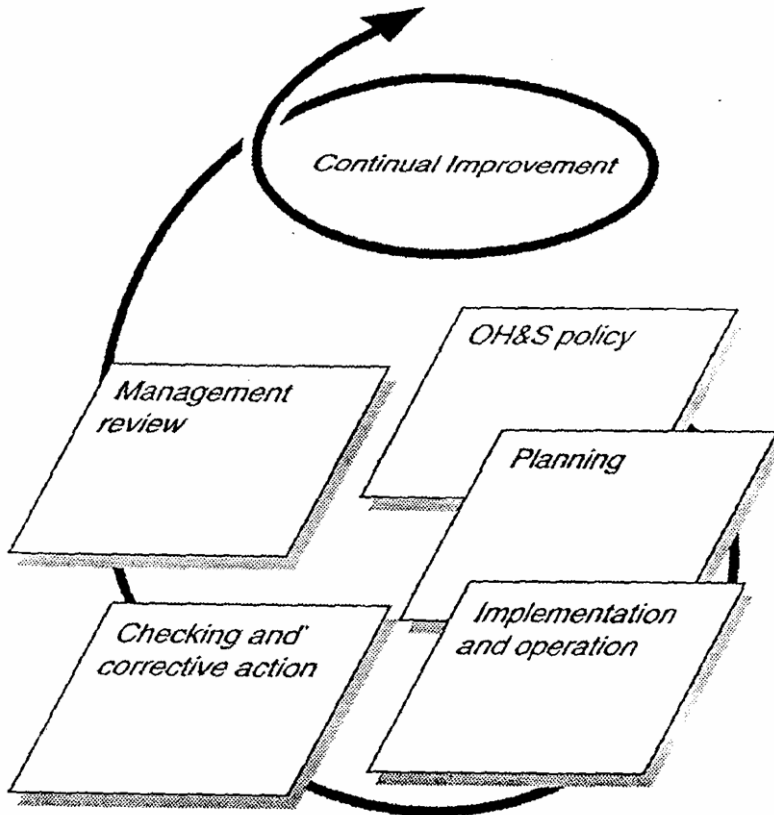
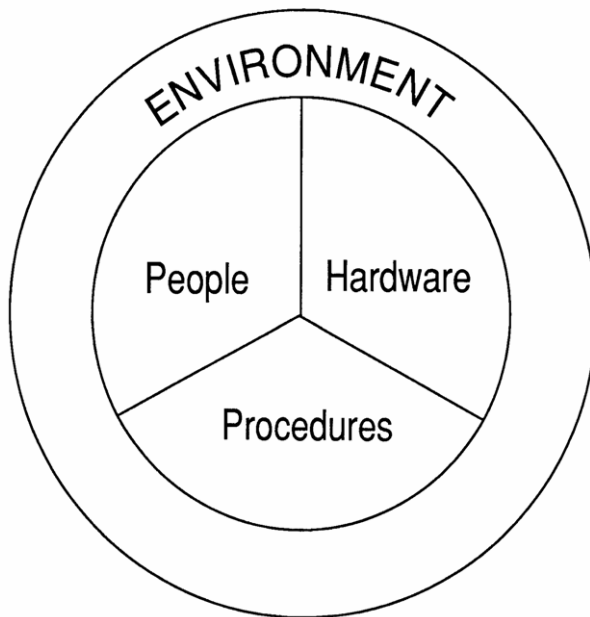

Figure 1 — Elements of successful OH&S management

- Commitment
- **PLAN** – Hazard Identification and Risk Assessment ...
- **DO** - Responsibilities, Training, Communication, Documentation, Risk Controls, Emergencies ...
- **CHECK** – Inspections, Fixes, Investigations, Records
- **ACT** - Monitor, Audits ...
- Continuous Risk Reduction

Alternative Fuels Station Safety Plan

THE NERTNEY MODEL



- Four major components can interact with each other.
- Interface between components must be assessed

- A broad approach to Risk Management
- Quality Components
- Quality Interfaces
- **INTEGRATION** with Site Safety Management System

Safety Analyses

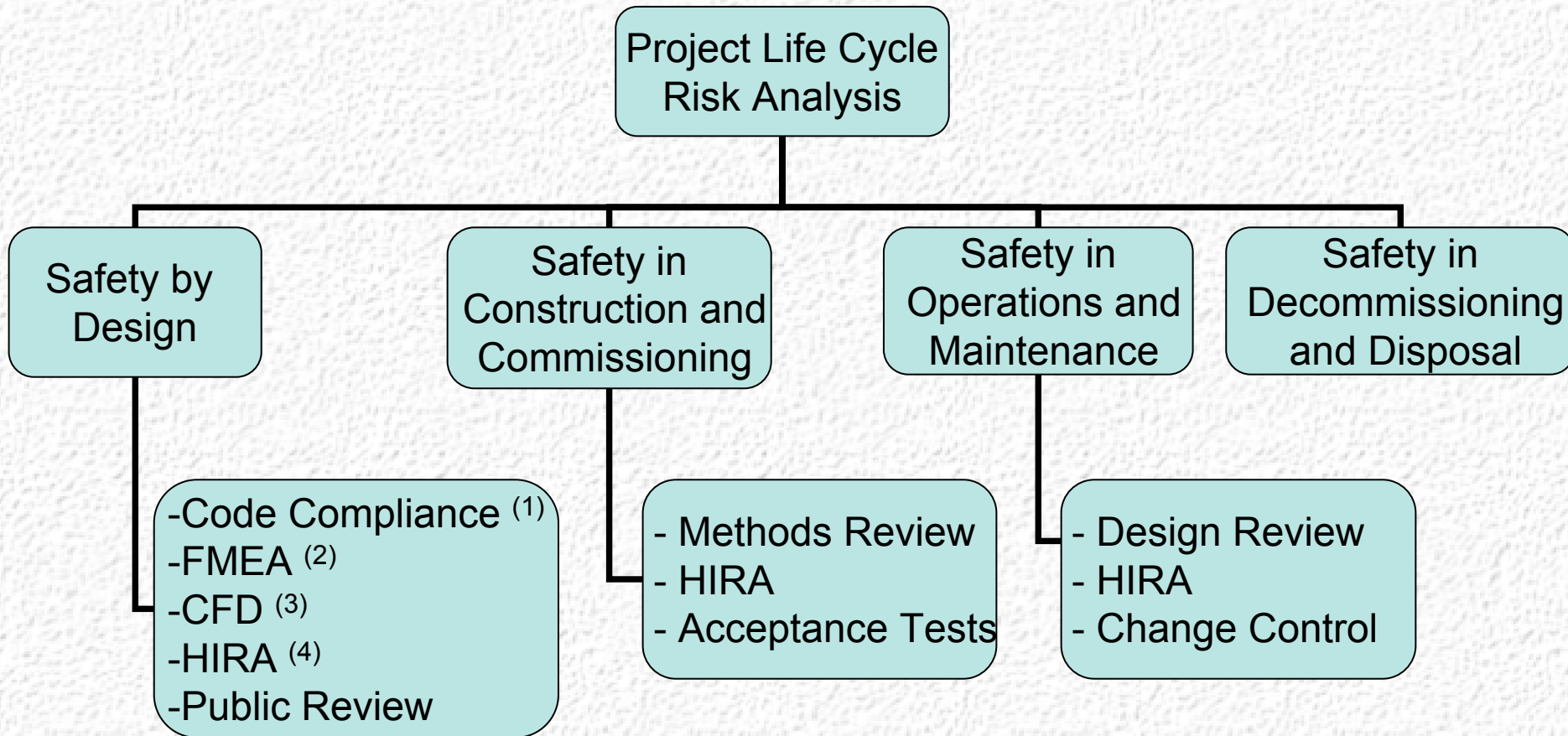

(1) Eg NFPA 52, 55, 70

(2) Failure modes and effects analysis

(3) Computational fluid dynamics analysis

(4) Hazards identification and risk analysis

Critical Site Work Procedures

- Risk Assessment
- Work Planning
- Contractor Safety
- Work Permits
 - Isolation & De-energization, etc.
- Safety Deficiency Reporting
- Site Emergency Plan

Alternative Fuels Platform

Gaseous Control Panels
(N₂, NG GCP, H₂ GCP)

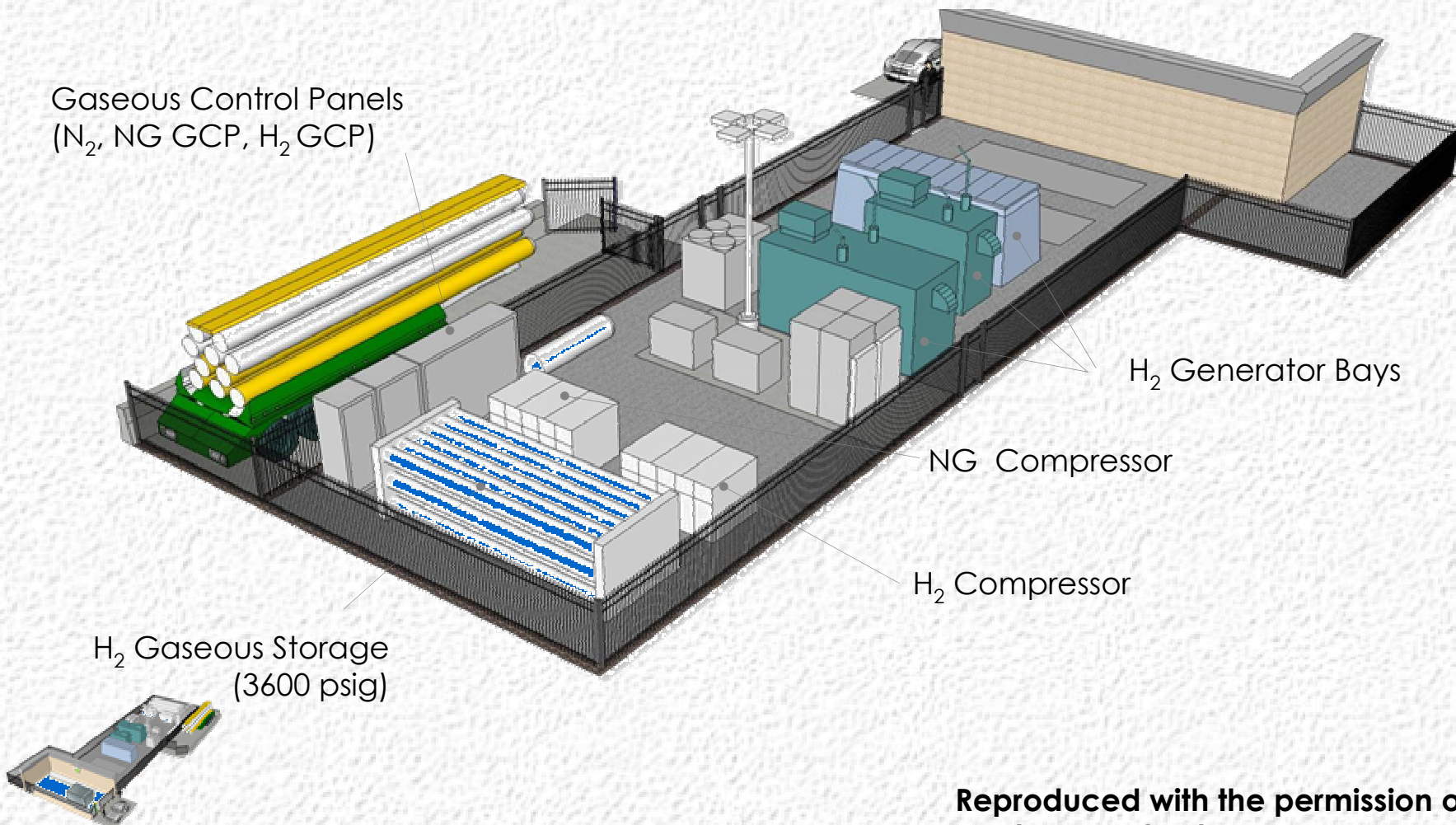

H₂ Generator Bays

NG Compressor

H₂ Compressor

H₂ Gaseous Storage
(3600 psig)

Reproduced with the permission of
NextEnergy Center

Alternative Fuels Platform



H₂ Fuel Dispenser

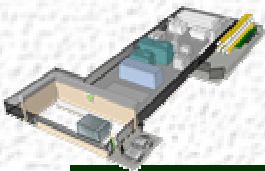

Reproduced with the permission of
NextEnergy Center

Code Compliance

The core value of engineering is public safety and codes and standards are fundamental. Codes and standards for alternative fuels are still developing and the local Authority Having Jurisdiction (AHJ) is often not familiar with them. Clearly demonstrating to the local AHJ and all stakeholders that the Alternative Energy installation “meets code” is an essential step in the design process.

Sample Code Compliance Table (e.g. NFPA 52:2006 & NFPA55:2005)

DISTRIBUTOR'S TRANSFER PANEL / GASEOUS H2 STORAGE> 15,000 scf - PHYSICAL SETBACKS

ID	D	CODE	DESCRIPTION
D21	3	NFPA 52:9.3.1.3.9	VALVES AND FITTINGS OF MULTIPLE GROUPS OF CONTAINERS FROM ANY OBSTRUCTION
D22	3	NFPA 52:9.3.1.3.8	FROM POINT OF TRANSFER
D23	5*	NFPA 55: 10.3.2.2.1 (1)(A) 1.	FROM A SPRINKLERED BUILDING WITH WALLS CONSTRUCTED OF NON-COMBUSTIBLE OR LIMITED COMBUSTIBLE MATERIAL
D24	5*	NFPA 55: 10.3.2.2.1 (1)(A) 1.	FROM AN UNSPRINKLERED BUILDING HAVING NON-COMBUSTIBLE CONTENTS AND WALLS CONSTRUCTED OF NON-COMBUSTIBLE OR LIMITED COMBUSTIBLE MATERIAL
D25	5*	NFPA 55: 10.3.2.2.1 (1)(A) 2. (b)	FROM AN UNSPRINKLERED BUILDING WITH COMBUSTIBLE CONTENTS AND WITH WALLS OF FIRE RESISTANCE => 2 HOURS
D26	5*	NFPA 55: 10.3.2.2.1 (14)	FROM THE LINE OF ADJOINING PROPERTY THAT IS ABLE TO BE BUILT UPON
D27	5	NFPA 55: 10.3.2.2.1 (15) (B)	HORIZONTAL DISTANCE FROM THE VERTICAL PLANE BELOW THE NEAREST OVERHEAD ELECTRIC WIRE OTHER THAN AN ELECTRIC TROLLEY, TRAIN OR BUS LINE
D28	10	NFPA 52: 9.3.1.3.1	FROM THE NEAREST IMPORTANT BUILDING
D29	10	NFPA 52: 9.3.1.3.1	FROM THE LINE OF ADJOINING PROPERTY THAT CAN BE BUILT UPON
D30	10	NFPA 52: 9.3.1.3.1	FROM ANY SOURCE OF IGNITION
D31	10	NFPA 52: 9.3.1.3.2	FROM THE NEAREST PUBLIC STREET OR SIDEWALK LINE
D32	10	NFPA 52: 9.3.1.3.4	FROM READILY IGNITABLE MATERIAL
D33	10	NFPA 55: 10.3.2.2.1 (2) (A)	FROM WALL OPENINGS NOT ABOVE ANY PART OF A SYSTEM
D34	10*	NFPA 55: 10.3.2.2.1 (4) (A)	FROM AN UNDERGROUND TANK, 0-1000 GALLONS CONTAINING ANY CLASSES OF FLAMMABLE AND COMBUSTIBLE LIQUIDS (i)FROM PUBLIC SIDEWALKS (ii)FROM PARKED VEHICLES
D35	15	NFPA 55: 10.3.2.2.1 (13)	FROM OVERHEAD PIPING CONTAINING OTHER HAZARDOUS MATERIALS
D36	15	NFPA 55: 10.3.2.2.1(13)	FROM ABOVE GROUND TANKS CONTAINING FLAMMABLE OR COMBUSTIBLE LIQUIDS
D37	15	NFPA 55: 10.3.2.2.1 (15) (C)	FROM ANY UNDERGROUND STORAGE TANKS, >1000 GALLONS CONTAINING ANY CLASS OF FLAMMABLE OR COMBUSTIBLE LIQUID
D38	20	NFPA 52: 9.3.1.3.5	FROM AN UNSPRINKLERED BUILDING WITH COMBUSTIBLE CONTENTS AND WITH WALLS OF FIRE RESISTANCE < 2 HOURS
D39	20*	NFPA 55: 10.3.2.2.1 (5) (A)	FROM AN ABOVE GROUND TANK, 0-1000 GALLONS CONTAINING ANY CLASS OF FLAMMABLE OR COMBUSTIBLE LIQUID
D40	25*	NFPA 55: 10.3.2.2.1 (1) (A) 2 (a)	FROM THE VENT OR FILL OPENING OF ANY TANK CONTAINING ANY CLASS OF FLAMMABLE OR COMBUSTIBLE LIQUID
D41	25	NFPA 55: 10.3.2.2.1 (2) (B)	FROM WALL OPENINGS ABOVE ANY PART OF THE SYSTEM
D42	25*	NFPA 55: 10.3.2.2.1 (3) (A)	FROM AN ABOVE GROUND TANKS 0-1000 GALLONS CONTAINING ANY CLASS OF FLAMMABLE OR COMBUSTIBLE LIQUID
D43	25*	NFPA 55: 10.3.2.2.1 (4) (B)	FROM THE VENT OR FILL OPENING OF ANY TANK CONTAINING ANY CLASS OF FLAMMABLE OR COMBUSTIBLE LIQUID
D44	25*	NFPA 55: 10.3.2.2.1 (5) (B)	FROM FLAMMABLE GAS STORAGE OTHER THAN H2, 0-15000 scf
D45	25*	NFPA 55: 10.3.2.2.1 (6) (A)	FROM SLOW BURNING SOLIDS
D46	25*	NFPA 55: 10.3.2.2.1 (9)	FROM OPEN FLAMES AND WELDING
D47	25*	NFPA 55: 9.3.2 (12) (iv)	FROM BULK LIQUID OXYGEN STORAGE IF GAS H2 STORAGE IS <= 25000 scf
D48	50	NFPA 52: 9.3.1.3.3	FROM THE NEAREST TRACK OF ANY RAIL ROAD MAIN TRACK
D49	50*	NFPA 55: 10.3.2.2.1 (1) (B)	FROM A BUILDING WITH WALLS CONSTRUCTED OF OTHER THAN NON-COMBUSTIBLE OR LIMITED COMBUSTIBLE MATERIAL
D50	50*	NFPA 55: 10.3.2.2.1 (3) (B)	FROM AN ABOVE GROUND TANK, >1000 GALLONS CONTAINING ANY CLASS OF FLAMMABLE OR COMBUSTIBLE LIQUID
D51	50*	NFPA 55: 10.3.2.2.1 (6) (B)	FROM FLAMMABLE GAS STORAGE OTHER THAN H2, >15000 scf
D52	50*	NFPA 55: 10.3.2.2.1 (8)	FROM FAST BURNING SOLIDS
D53	50	NFPA 55: 10.3.2.2.1 (11)	(i) FROM AIR COMPRESSOR INTAKES
D54	50	NFPA 55: 10.3.2.2.1 (11)	(ii) FROM HVAC INLETS
D55	50	NFPA 55: 10.3.2.2.1 (12)	FROM PLACES OF PUBLIC ASSEMBLY
D56	50	NFPA 55: 10.3.2.2.1 (15) (A)	FROM HORIZONTAL DISTANCE FROM THE VERTICAL PLANE BELOW THE NEAREST OVERHEAD WIRE OF AN ELECTRIC TROLLEY, TRAIN OR BUS LINE
D57	50*	NFPA 55: 9.3.2 (12) (v)	FROM BULK LIQUID OXYGEN STORAGE IF GAS SYSTEM IS >25000 scf

Physical Setbacks

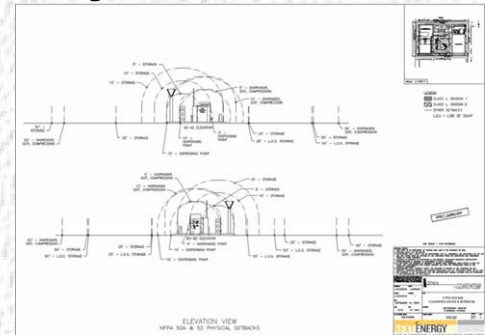

Classified Zones

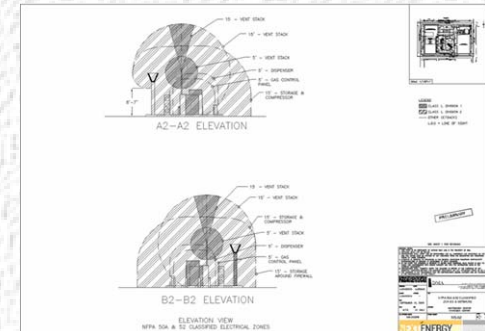

FMEA

- **A Failure Mode and Effect Analysis (FMEA) is a systematic method of identifying and preventing product and process problems before they occur. FMEA's are focused on preventing defects, enhancing safety and increasing customer satisfaction. FMEA's are conducted in the product design or process development stages, although conducting an FMEA on an existing product or process may also yield significant benefits.**

The FMEA standardizes the approach to product and process failure analysis. Its establishes a common language that can be used both within and between organizations. It can be understood by non-technical and technical persons at all levels.

The objective in Alternative Energy Infrastructure is "beyond code compliance" and FMEA is a necessary and useful tool.

(¹)adapted from the Basics of FMEA, ISBN 0-527-76320-9

FMEA

Example: A-04

Item	A) Device Quantity	Part Description	Part Function	Potential Failure Mode	Effect of Failure	B) Severity	Potential Causes of Failure	C) Occurrence	Current Detection / Prevention / Controls	D) Detection / Prevention / Control	Actual Risk Priority Number (AxBxCxD)	Maximum Potential Risk Priority Number (Ax1000)	Recommended Action
A-04	1	valve, isolation NO	manual isolation valve, 2 way shuts off hydrogen flow to the microgrid	Valve packing leaks internally	External leak into transfer panel during maintenance operations	2	* Wear and tear * Debris * Improper assembly	2	* Preventive maintenance * Certified installer for assembly * Enclosure is Class 1 Division 2 rated * Storage Enclosure designed to safely vent H2 to atmosphere	9	36	1000	
	1			Valve packing or threaded joints leak	H2 release into transfer panel	2	* Wear and tear * Debris * Improper assembly	2	* Preventive maintenance * Certified installer for assembly * Limited flow rate from excess flow valve * Valve located outside in Storage Enclosure * Enclosure is Class 1 Division 2 rated * Storage Enclosure designed to safely vent H2 to atmosphere	9	36	1000	

Summary:

FMEA Priority Risk Number (PRN) Summary

Actual PRN
XXXXX

Maximum Potential PRN
XXXXX

PRN Quotient

XXXXX

Releases at Refuelling Stations

CFD

Computational Fluid Dynamics is the science of predicting what will happen, quantitatively when fluids flow. Fluid flows are computer modeled by the numerical solution of the governing partial differential equations or other mathematical equations of motion.

CFD modeling is a useful tool in the design of Alternative Energy installations in congested urban settings to determine the outcomes of incidents such as a “jet fire” or high pressure release of a compressed gas or cryogenic liquid fuel.

DMA works with A. V. Tchouvelev & Associates, Center for Hydrogen Safety and Codes and Standards™ whenever the project calls for CFD modeling.

Releases at Refuelling Stations

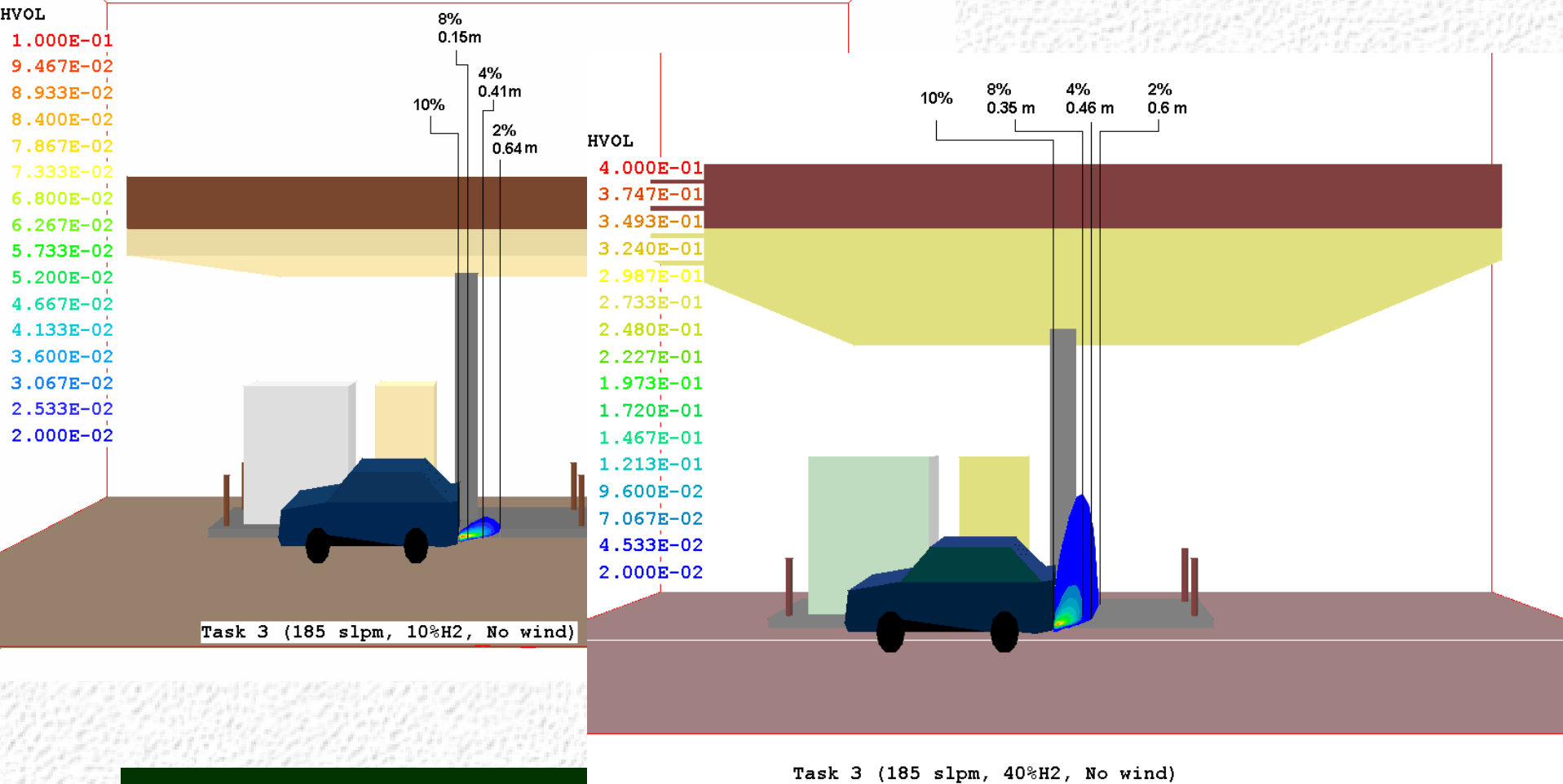

H₂ Releases from Piping Outdoors

20 CFM, 400 bars, vertical and horizontal:

HVOL

- 8.000E-02
- 7.600E-02
- 7.200E-02
- 6.800E-02
- 6.400E-02
- 6.000E-02
- 5.600E-02
- 5.200E-02
- 4.800E-02
- 4.400E-02
- 4.000E-02
- 3.600E-02
- 3.200E-02
- 2.800E-02
- 2.400E-02
- 2.000E-02

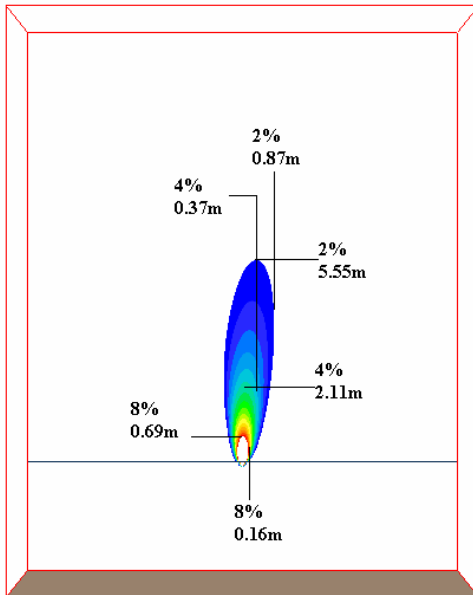

HVOL

- 8.000E-02
- 7.600E-02
- 7.200E-02
- 6.800E-02
- 6.400E-02
- 6.000E-02
- 5.600E-02
- 5.200E-02
- 4.800E-02
- 4.400E-02
- 4.000E-02
- 3.600E-02
- 3.200E-02
- 2.800E-02
- 2.400E-02
- 2.000E-02

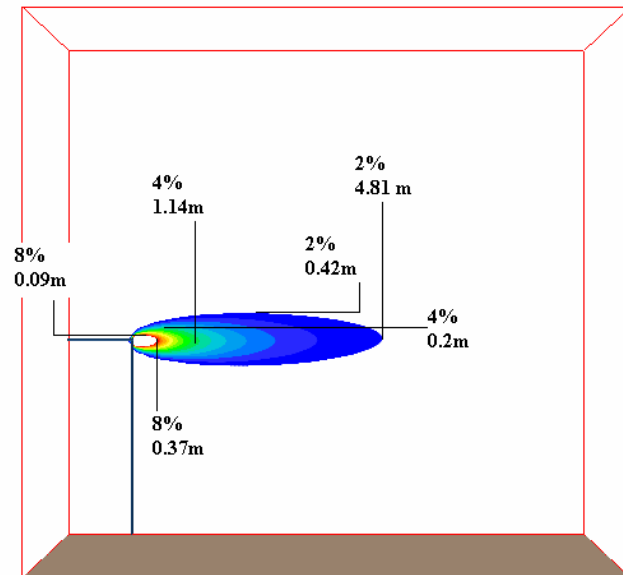

Room Ventilation Requirements: Slow Release

Hydrogen release rates:

Constant 5 CFM and 2.5 CFM

Leak orifice: 1"

Container: 8'×8'×12'

*Flow pattern: subsonic
laminar*

Exhaust fan : 2500 CFM

Over-roof duct :

10.82'×1.525'×1.15'

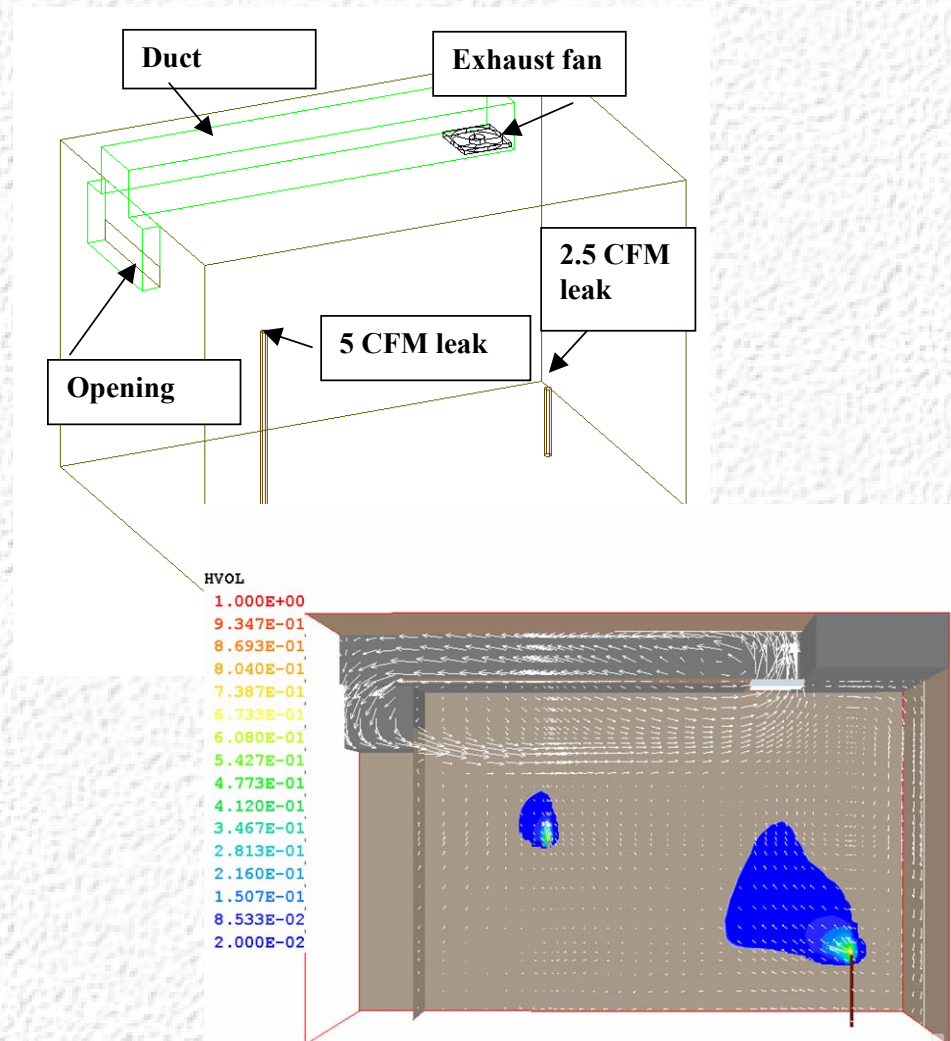

HIRA – Hazard Identification and Risk Assessment

HIRA (Sample)

Introduction

Provides a brief description of the station under construction and special conditions or limitations on the scope of the analysis.

Definitions

HIRA is a semi-quantitative risk analysis. It is intended to be a preliminary screening process to determine priorities and identify risks worthy of more detailed quantitative risk analysis. By definition, Risk = Probability X Consequence. Suggested estimators for Probability and Consequence are based on U.S. Military specification 882 on Risk Assessment and shown in Figure 1.

HIRA

Figure 1A: Probability

DESCRIPTION (events over a lifetime)	LEVEL
Frequent $P > 10^{-1}$, continuous	A
Probable $P > 10^{-2}$, regular	B
Occasional $P > 10^{-3}$, several	C
Remote $P > 10^{-6}$, few	D
Improbable $P < 10^{-6}$, one	E

Figure 1B: Consequence

DESCRIPTION	CATEGORY
Catastrophic (Death, \$1M loss, major spill, etc.)	1
Critical (Serious injury, >\$200K loss, etc.)	2
Marginal (Lost time injury, >\$10k loss, etc.)	3
Negligible (Minor injury, >\$2k loss, etc.)	4

The definitions in Figure 1 are guidelines and should be modified over time to best fit company experience. If in doubt, be conservative and rank either probability or consequence at a higher level or category pending more detailed analysis.

HIRA – Hazard Identification and Risk Assessment Worksheet

Hazard ID (Energy, Checklists)	Existing Controls (Barriers)	Risk Estimate (P X C)	Risk Assessment Matrix	Action/ Comments
Gravity				
Electrical				
Mechanical				
Etc.				

Risk Assessment Matrix

<i>Severity</i>	I Catastrophic	II Critical	III Marginal	IV Negligible
<i>Frequency</i>				
A - Frequent	1A Unacceptable	2A Unacceptable	3A Unacceptable	4A Acceptable*
B - Probable	1B Unacceptable	2B Unacceptable	3B Undesirable	4B Acceptable*
C - Occasional	1C Unacceptable	2C Undesirable	3C Undesirable	4C Acceptable
D - Remote	1D Undesirable	2D Undesirable	3D Acceptable*	4D Acceptable
E - Improbable	1E Acceptable*	2E Acceptable*	3E Acceptable*	4E Acceptable

HIRA – Sample Worksheet

Hazard ID (Energy)	Existing Controls (Barriers)	Risk Estimate (P X C)	Risk Assess't Matrix	Action/ Comments
Construction "Dig-in" to: -H ₂ Piping -H ₂ Cable	-Work Plan -drawings -depth / fill -warning tape -concrete -operator skill	Remote X Catastrophic = 1D	Yellow Zone or Undesirable	-Dig permit -Locate proc. ↓ Green Zone or Acceptable*
Etc.				

DMA Operational Readiness Checklist

- Part 1 Administration**
 - 1. Best Practices
- Part 2 Equipment**
 - 1. Shop Drawings
 - 2. Cut Sheets
- Part 3 Station Design**
 - 1. As-Built Drawings
- Part 5 Approvals**
 - 1. Code Compliance Document (UL, CSA, CE PED)
 - 2. Factory Acceptance Tests
 - 3. Pressure Tests
 - 4. Electrical Tests
 - 5. Site Acceptance Tests
 - 6. AHJ Certifications
 - 1. Project Acknowledgement
 - 2. Design Approval
 - 3. Construction Inspections
 - 4. Final Approvals
- Part 6 Safety**
 - 1. Project Safety Plan
 - 2. Design Risk Analysis
 - 3. Construction Risk Analysis
 - 4. Operational Risk Analysis
 - 5. Disposal Risk Analysis
 - 6. Operational Readiness Checklist
- Part 7 Manuals**
 - 1. ERP
 - 2. SOM
 - 3. VOM
 - 4. SO&MM
 - 5. Signage
- Part 8 Warranty**
 - 1. Certificate of Substantial Completion

References

- The Sourcebook for Hydrogen Applications
www.tisec.com
- Regulators Guide to Permitting Hydrogen Technologies
www.energy.gov
- National Fire Protection Association
www.nfpa.org
- International Organization for Standardization
www.iso.org
- Canadian Standards Association
www.csa.ca